

Approval Specification

Customer :

Product: Thick Film High Ohmic Chip Resistor

CR-02 $\pm 1\%$ & $\pm 5\%$

Sizes : 0402

Approval Date. : _____

Customer Approval :

(please sign & return)



TMTEC CO., LTD.

Headquarters

Tel: +886 7 8217999
Fax: +886 7 8228229
No.248-3, Sin-Sheng Rd.,
Cian-Jhen Dist.,Kaohsiung, Taiwan, 806
Web site: www.tmtec.com.tw

Taipei Sales Office

Tel: +886 2 82281578
Fax: +886 2 82282128
6F, No.872, Jhong-Jheng Rd.,
Jhonghe city, Taipei County, Taiwan 235



1. Features

- Reduced Size of Final Equipment
- Low Assembly Costs
- Higher Component and Equipment Reliability
- High Maximum Permissible Voltage

2. Applications

- Measuring Equipment
- Telecommunication Equipment
- Computers
- Television

3. Description

The resistors are constructed on the alumina substrate. Top electrodes are added to each end and connected with resistive paste that is applied to top surface of the alumina substrate. The resistive layer is made by resistive paste that is prepared to approach the nominal value. Laser trimming process makes the resistance value to meet the nominal value and within the tolerance.

The resistive layer is protected by primary overcoat and secondary overcoat. Marking on secondary overcoat let user to know the resistance value directly. The barrier layer is added to edge electrodes for plating with external electrode that is the main role makes the resistor mounted on PCB.

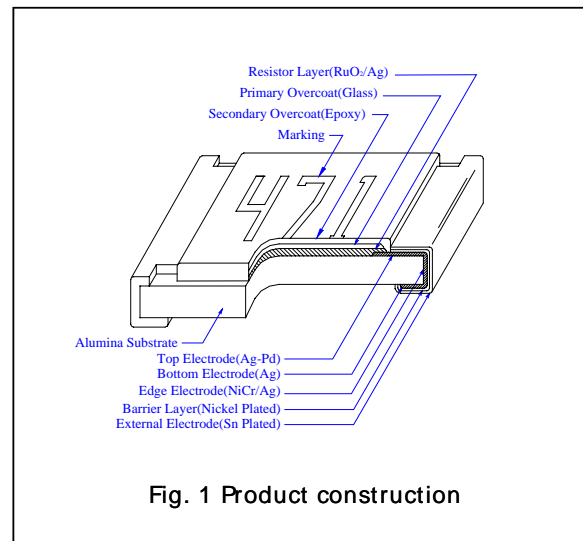

4. Quick Reference Data

Type name	CR-02
Size code	0402
Resistance tolerance	±5%(E24 series) ; ±1%(E24, E96 series)
Resistance range	±1%: 11MΩ~20MΩ ±5%: 11MΩ~39MΩ
Temperature Coefficient of Resistance (ppm/°C)	±5% ±1%
R ≤ 20MΩ	±200 ±200
22M ≤ R ≤ 39MΩ	±400 -
Power rating (at 70°C)	1/16W
Max. operation voltage (DC or RMS)	50V
Max. overload voltage	100V
Jumper Rated current	1A
Climatic category (IEC 60068)	55/125/42



5. Order information

Digits	1	2	3	4	5	6	7	8	9	10	11	12	13	14
Order Code	C	R	-	0	2	J	L	6	-	-	-	1	2	M
	Type Name CR-02: 0402					Tolerance J : ±5% F : ±1%	Function code - : Normal L : Lead Free	Packaging 6 : 7" reel, paper tape, 10000 pcs/reel B : 10" reel, paper tape, 20000 pcs/reel C : 13" reel, paper tape, 40000 pcs/reel - : Not Applicable	Resistance Value ---12M : 12MΩ ---18M : 18MΩ ---20M : 20MΩ ---24M : 24MΩ					

6. Functional description

Derating curve

For resistors operate in the ambient temperature over 70°C, loading power ratio will derate in accordance with following curve.

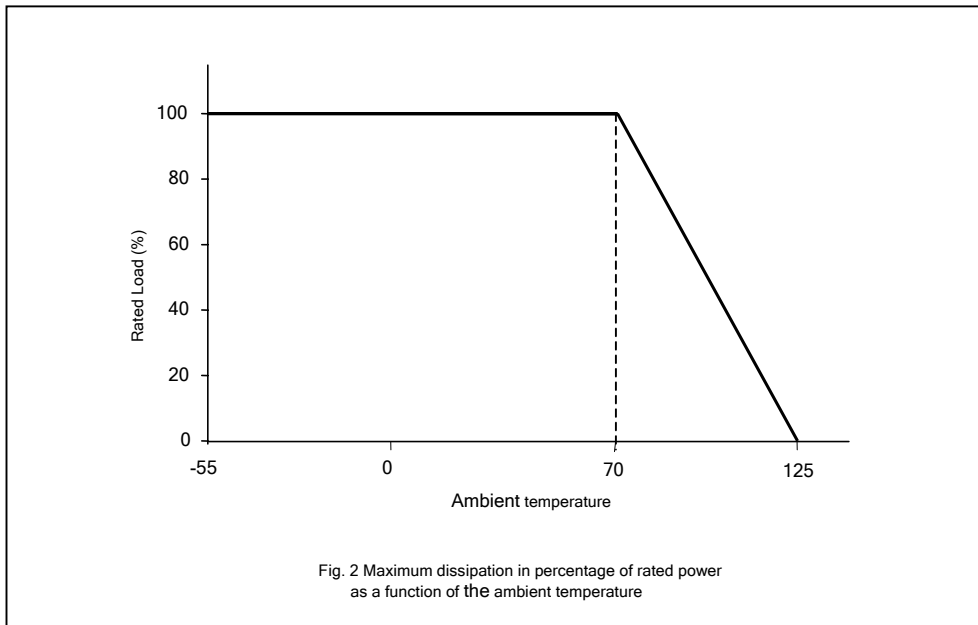



Soldering condition

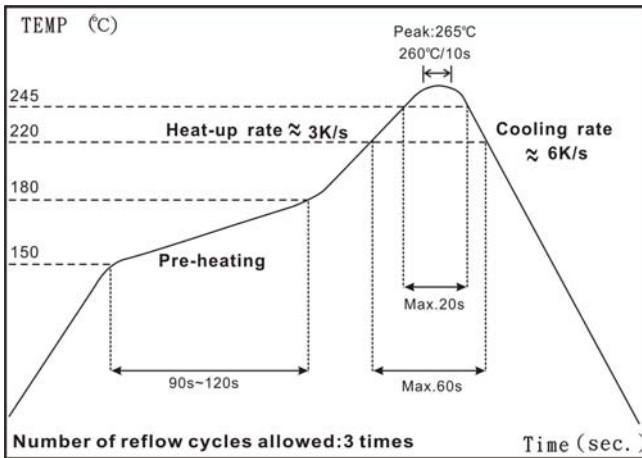

Fig.3 IR Reflow Soldering

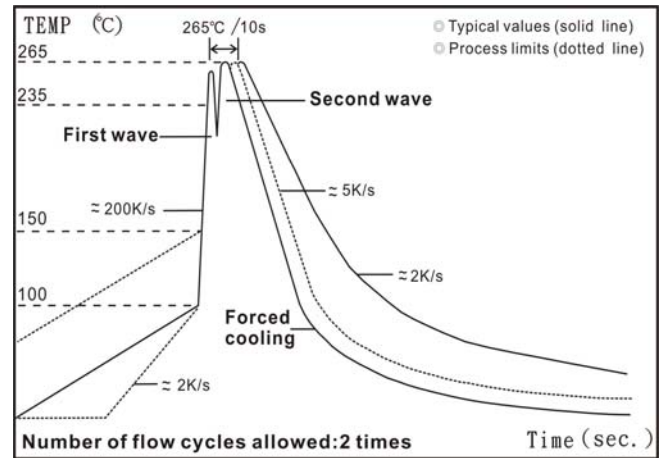

Fig.4 Wave Soldering (Flow Soldering)

7. Mechanical Data

Dimension

Type	CR-02
L (mm)	1.00±0.05
W (mm)	0.50±0.05
H (mm)	0.35±0.05
A (mm)	0.20±0.10
B (mm)	0.20±0.10

Mass per 1000 pcs

TYPE NAME	MASS (g)
CR-02	0.58

Outline

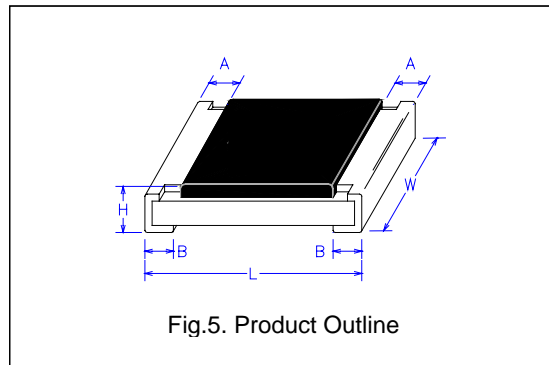

Fig.5. Product Outline

Marking

Type A: CR-02 is without marking due the size is too small.

The marking example is as table 1.

Table 1 Making code example

Type	Product	Value	Example
A	CR-02, ±1, ±5%	N/A	



8. Test And Requirements

In table 3 the tests and requirements are listed with reference relevant clause of IEC 60115-1. A short description of the test procedure is given. Essentially all tests are carried out refer to the schedule of IEC 60115-8-1. The testing also covers the requirements specified by EIA.

Table 3 Test procedure and requirements

Test Item	Test Method	Test Condition	Requirement	
			±1%	±5%
Temperature Coefficient of Resistance(T.C.R.)	JIS C 5202 5.2 IEC 60115-1 4.8	-55°C~+125°C ,20°C is the reference temperature	Within the specification	
Short Time Overload	JIS C 5202 5.5 IEC 60115-1 4.13	2.5 times RCWV or Max. overload voltage , for 5 seconds	±1.0%	±2.0%
Insulation Resistance	JIS C 5202 5.6 IEC 60115-1 4.6	Max. overload voltage for 1 minute	≥10G	
Voltage Proof	JIS C 5202 5.7 IEC 60115-1 4.7	1.42 times RCWV (RMS) for 1 minute	no breakdown or flashover	
Substrate Bending Test	JIS C 5202 6.1 IEC 60115-1 4.33	Bending once with 5 seconds for 3mm	±1.0%	±1.0%
Resistance to soldering heat	JIS C 5202 6.4 IEC 60115 4.18	260±5°C for 10 seconds	±0.5%	±1.0%
Leaching	JIS C 5202 6.4 IEC 60115 4.18	260±5°C for 60 seconds	no leaching	
Solderability	JIS C 5202 6.5 IEC 60115-1 4.17	245±5°C for 3 seconds.	>95% coverage	
Endurance at upper category temperature	JIS C 5202 7.2 IEC 60115-1 2.23.2	At +125°C for 1000 hrs	±1.0%	±1.5%
Rapid change of temperature	JIS C 5202 7.4 IEC 60115-1 4.19	-55°C to +125 °C, 5 cycles	±0.5%	±1.0%
Damp heat with load	JIS 5202 7.9	40±2°C, 90~95% R.H. or Max. working voltage for 1000 hrs with 1.5hrs "ON" and 0.5 hrs "OFF"	±2.0%	±3.0%
Endurance	JIS C 5202 7.10 IEC 60115-1 4.25.1	70±2°C, or Max. working voltage for 1000 hrs with 1.5 hrs "ON" and 0.5 hrs "OFF"	±2.0	±3.0

Note:

RCWV : Rated continuous working voltage .

$$RCWV = \sqrt{\text{Rated power} * \text{Resistance value}}$$

